

1 2 3 4 5 6 7 8

A

A

B

B

C

C

D

D

E

E

F

F

3

2

1

4

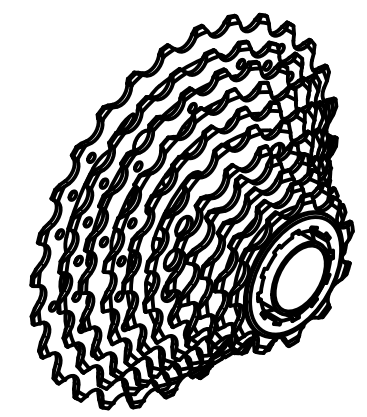
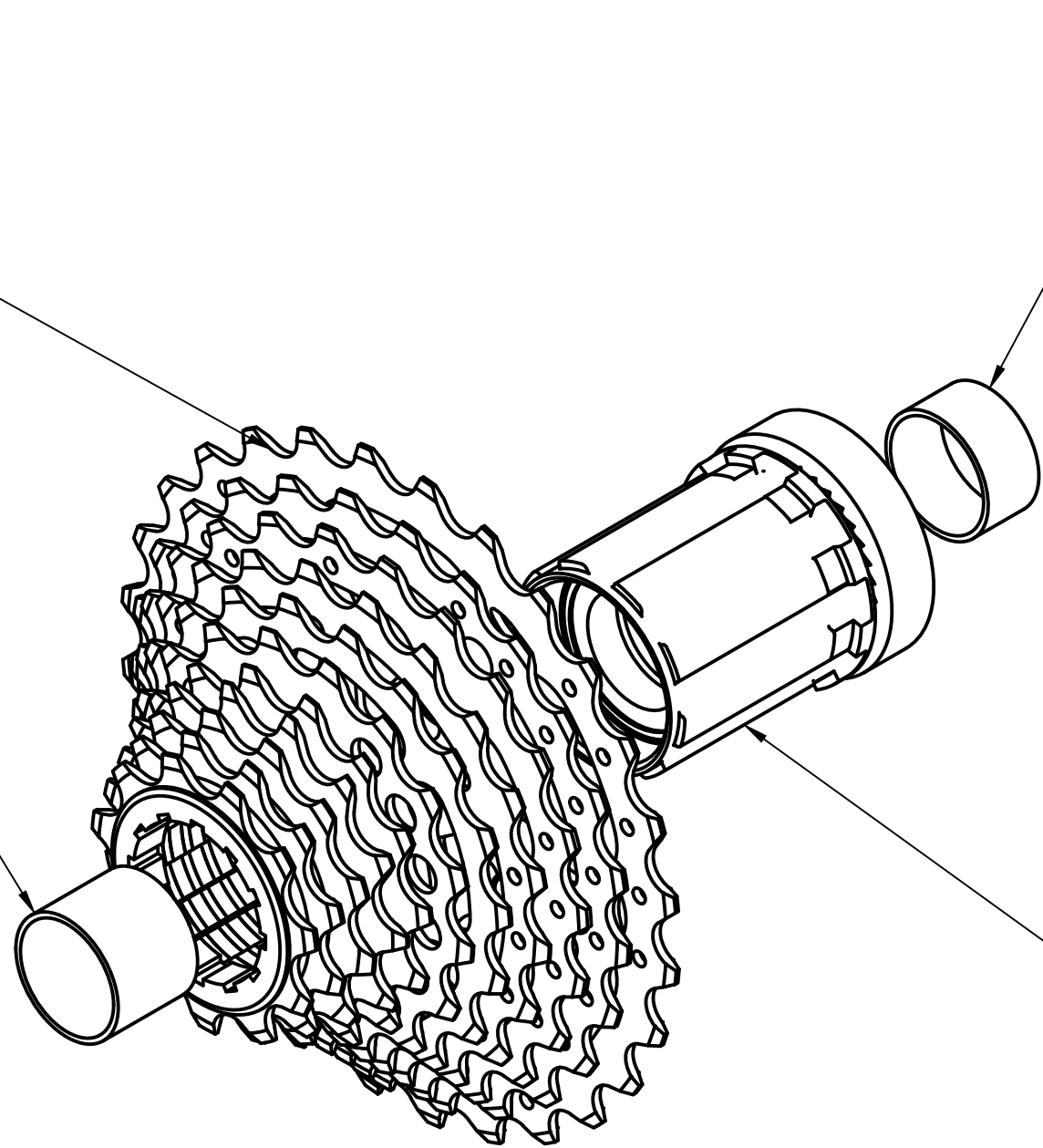

Parts List					
Item	Part Number	Part Name	Qty	Description	
1	SN_00_RS_P203	Spacer+	1		
2	SN_00_RS_P202	Spacer -	1		
3	SN_00_RS_A003	Cassette	1		
4	SN_00_RS_A004	Fulcrum freewheel	1		
Dept.		Technical reference	Created by Flaviu Cioloca 06.06.2023	Approved by	
		Document type		Document status	
		Title		Project Snoek	Scale 1:2
		DWG No. Cassete+fulcrum		Rev.	Date of issue

1 2 3 4 5 6 7 8

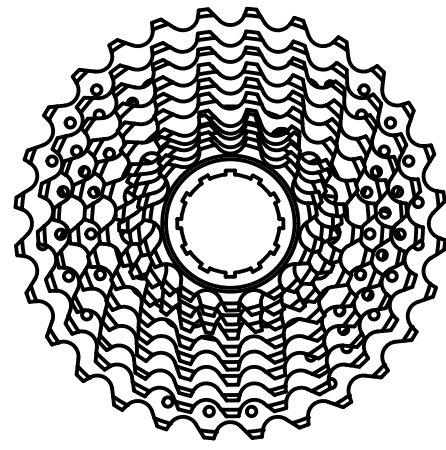

Parts List				
Item	Part Number	Part Name	Qty	Description
1	Cassette11	Cassette11	1	
2	Cassette12	Cassette12	1	
3	Cassette13	Cassette13	1	
4	Cassette14	Cassette14	1	
5	Cassette15	Cassette15	1	
6	Cassette17	Cassette17	1	
7	Cassette19	Cassette19	1	
8	Cassette21	Cassette21	1	
9	Cassette23	Cassette23	1	
10	Cassette25	Cassette25	1	

Dept.	Technical reference	Created by	Approved by
		Clara Loca 06.06.2023	
		Document type	Document status
			1
		Project	Scale
		Snoek	1:2
		Rev.	Date of issue
			Sheet
			2/3



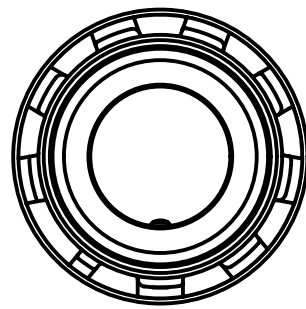

Parts List				
Item	Part Number	Part Name	Qty	Description
1	Caessette Body	Caessette Body	1	
2	Bearing 1	Bearing 1	2	
3	Spacer 1	Spacer 1	1	
4	Fulcrum ring	Fulcrum ring	1	
5	BU...EUR_	Bearings spacer	1	
6	DF/DFXL02 FU R P 006	Spacer safety ring	1	

Dept.	Technical reference	Created by	Approved by		
		Fabian Cingca	06.06.2023		
		Document type	Document status		
			1		
		Title	Project	Scale	
			Snoek	1:1	
		DWG No.	Rev.	Date of issue	Sheet
		Cassete+fulcrum			3/3

